

Specialists in endoscope reprocessing since 1984!



WASSENBURG® WD440

Toploader endoscope washer-disinfector

Optimum process assurance

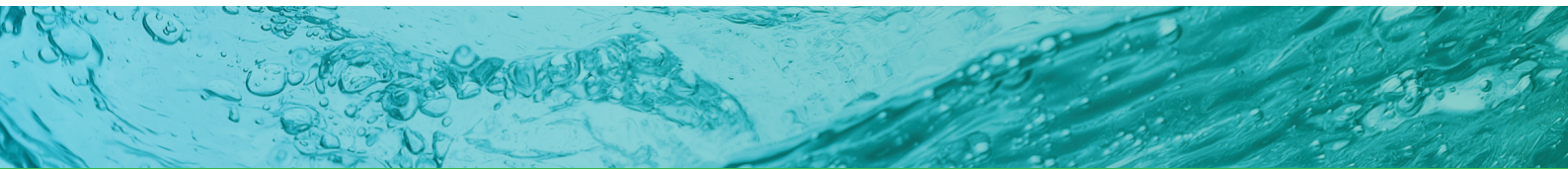

A SAFE ENDOSCOPE FOR EVERY PATIENT

Wassenburg Medical is a leader in endoscope reprocessing. We have been developing innovative solutions with one goal since 1984: to provide a safe endoscope for every patient. This has resulted in a range of products and solutions that cover the full spectrum of endoscope reprocessing: a total solution.

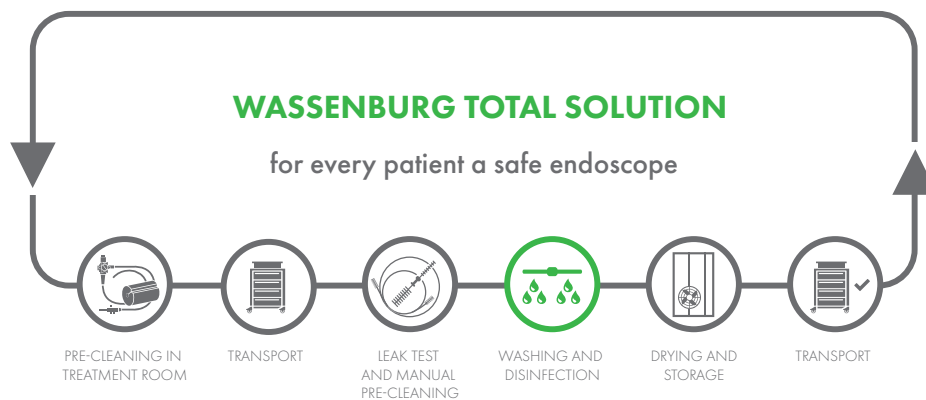

The WASSENBURG® WD440 is designed for controlled cleaning and disinfection of flexible endoscopes and other thermolabile medical devices. Our user-friendly WASSENBURG® WD440 provides you with the highest control- and safety levels. Equipped with either polypropylene or stainless steel basins, the WASSENBURG® WD440 offers an optimum cleaning performance.



Stainless steel basins

or



Polypropylene basins





COMPLIANCE

The WASSENBURG® WD440 is fully compliant to ISO 15883 and contains an IMS that is fully independent from the process controller. All WASSENBURG® washer-disinfectors are CE-marked (NB no. 2797), fulfil the General Safety and Performance Requirements of Medical Device Regulation (EU) 2017/745 and are compliant with ISO 15883 part 1 and part 4.

OPTIMUM SAFETY

To ensure complete cleaning and disinfection of endoscopes, the WASSENBURG® WD440 contains a unique basin and helical tube system. Fluid flow in the helical tube lifts the distal end from the wall, allowing fluid to contact it everywhere.

Proven Wassenburg individual channel pump- and connection technology is the core of the system. Each endoscope channel is reprocessed and controlled individually on connection, flow, pressure and blockage.

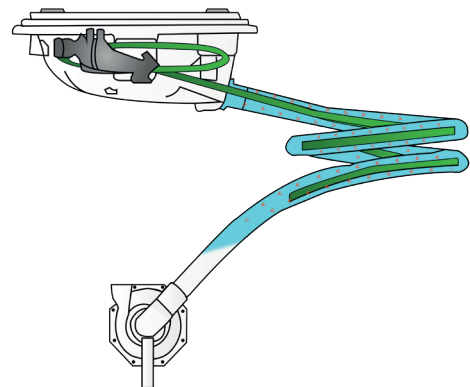

SAFEGUARDING THE PROCESS WITH RFID

To guarantee a safe and traceable appliance of process chemicals and bacterial filters, the WASSENBURG® WD440 is equipped with radio-frequency identification (RFID). Before starting a process, the WASSENBURG® WD440 will verify the right position of cans and filters and checks on exceeded expiry dates and other critical parameters, hereby minimising the risk of human error.

USER-FRIENDLY

The user interface of the WASSENBURG® WD440 is designed around intuitive and touchless operation. Handsfree operation of the lid, using foot sensors, means ease of use and reduces the risk of cross-contamination. The transparent lid allows the user to view inside the basin during the reprocessing cycle. Clear LED indicators in the machine indicate the status of the process. Colour-coded connection material facilitates easy and flawless endoscope connection, assisted by an intuitive colour touchscreen that guides the user through all necessary steps.

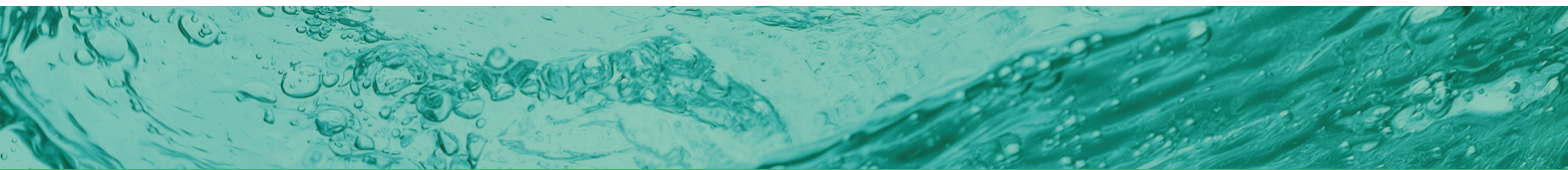

HIGH CAPACITY

Our EndoHigh® process chemicals – consisting of a detergent in combination with peracetic acid (PAA) or glutaraldehyde (GTA) – are exclusively developed for the WASENBURG® washer-disinfectors. All process chemicals are tested in vitro and type-tested according to ISO 15883. They provide an excellent and safe process performance, and a quick endoscope reprocessing cycle (22 minutes for PAA).

Two separate operating basins give easy access to individually loaded and connected endoscopes and prevent unnecessary waiting. The basins are specifically designed to minimise water consumption and to keep a constant process temperature. In addition, contact between the endoscope and the basin is kept to a minimum.

FULL TRACEABILITY

Our solutions are designed to contribute to a fully controlled and safe treatment of flexible endoscopes. Traceability is key to control your operation and necessary for compliance with guidelines. The integrated traceability supports the user in achieving compliance with applicable quality systems.



All steps of the cleaning and disinfection process in the WASENBURG® WD440 are traced and monitored in detail, with a report sent to an integral printer and optionally to our dedicated WASENBURG® Process Manager software. Process data is collected and provides meaningful information about all processes that have occurred in the washer-disinfector.

Process Manager works seamlessly with the WASENBURG® WD440 to comply with regulations and provides valuable insights into day-to-day operations, helping you to improve reliability and availability of your endoscopes.

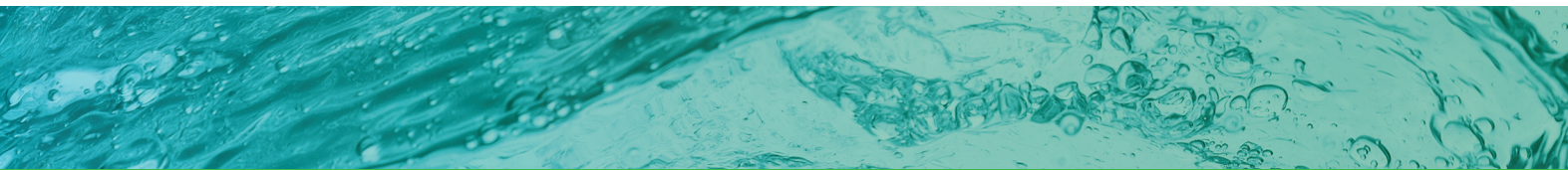

WASSENBURG® WD440 SPECIFICATIONS

Dimensions	W. 941 mm D. 750 mm H. 1033 mm lid closed, 1580 mm when lid open
Weight	200 kg (unloaded)
Sound level	60 – 65 dBA in use, 50 dBA not in use
Power requirements	220 – 240 V, 50 Hz / 60 Hz
Electrical connection	Plug with ground connection
Interface	Ethernet/TCP/IP
User interface	7.0" TFT Touchscreen
Min / max pressure	2.5 / 4 bar
Min flow rate water supply	10 l /min
Water usage	6 l per process step
Water quality	Potable



DESIGNED FOR COMPLIANCE

- ISO 15883-1 and ISO 15883-4
- EN1717: prevention of backflow
- Medical Device Regulation (EU) 2017/74



Wassenburg Medical B.V.
Edisonring 9
6669 NA DODEWAARD
THE NETHERLANDS

T: +31 (0) 488 700 500
F: +31 (0) 488 453 685
info@wassenburgmedical.nl
www.wassenburgmedical.com

© Copyright 2024. Subject to alterations.